

Measurement of Scattering Cross Sections of $^{\text{nat}}\text{Pb}$ and ^{209}Bi in the Energy Range from 2 MeV to 4 MeV

Erik Pönitz^{1,*}, Ralf Nolte¹), Dankwart Schmidt¹)

1) PTB Braunschweig

*) present adress: TU Dresden

Pb and Bi can play a bigger role in future nuclear facilities:

- **HCLL blanket for fusion reactors**
- **Gen-IV nuclear reactors: LFR (lead-cooled fast reactors)**
- **lead or lead-bismuth eutectic as coolant and spallation target for ADS (accelerator-driven system) for transmutation**

Embid et. al.: Sensitivity Analysis for ADS with Th+TRU fuel and liquid lead coolant and spallation source:

k_{eff} dependence on the cross section database

Material / database	k_{eff}
All JENDL 3.2	0.9444
All JENDL 3.2 except Pb (ENDF/B-VI)	0.9677

Important impact of k_{eff} on accelerator requirements !

Discrepancies in inelastic scattering cross sections

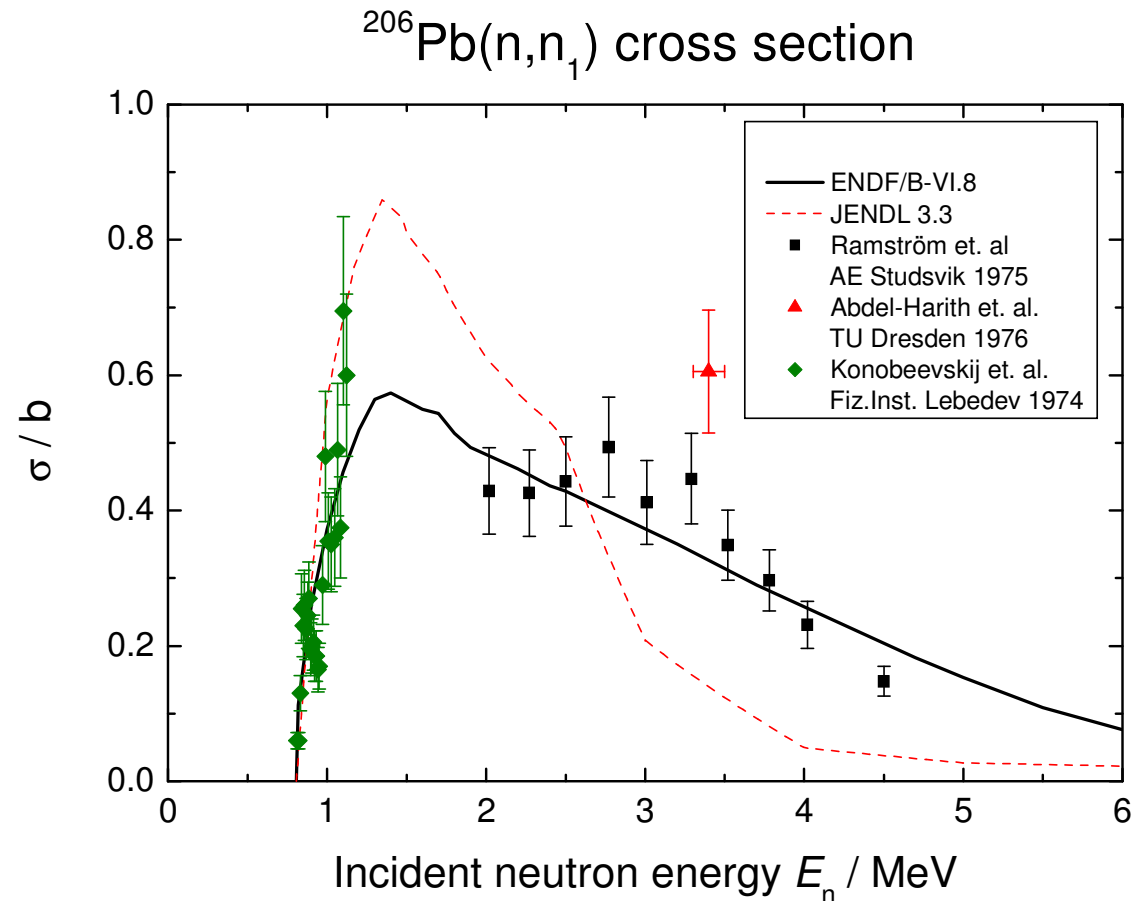

⇒ More and better experimental cross section data required!

PTB TOF Spectrometer

Detectors:

NE213 liquid scintillation detectors

D1: $\text{Ø } 4'' \times 1''$

D2 – D5: $\text{Ø } 10'' \times 2''$

Flight path: 12 m

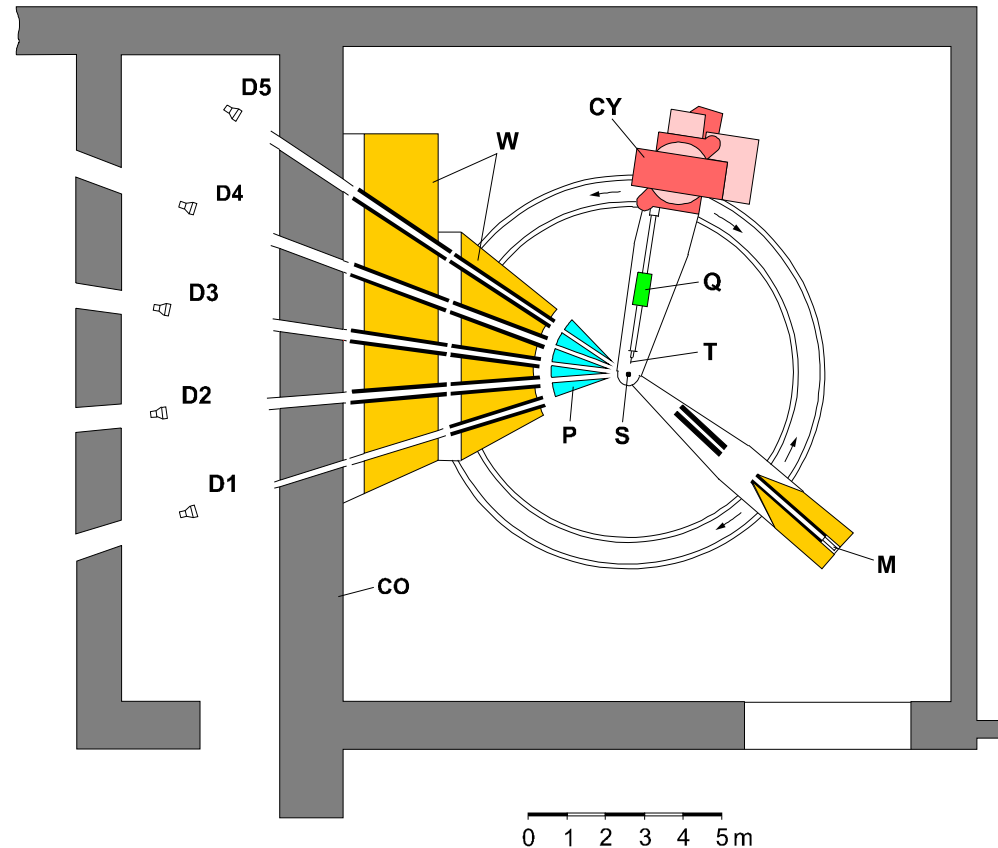

Projectile energies:

d 3 MeV – 13 MeV

p 2 MeV – 19 MeV

Reaction:

$D(d,n)$, $Q = +3.27$ MeV

$^{15}\text{N}(p,n)$, $Q = -3.54$ MeV

Energy range:

6 MeV – 15 MeV

PTB TOF Spectrometer



The $^{15}\text{N}(p,n)^{15}\text{O}$ Reaction

Advantages:

- stable
- monoenergetic neutrons
 $E_n \leq 5.7 \text{ MeV}$
- gas target allows background subtraction (gas-in/gas-out)

Disadvantages:

- cross section has strong resonance structure
- high energy loss
 $S = -dE/dx$

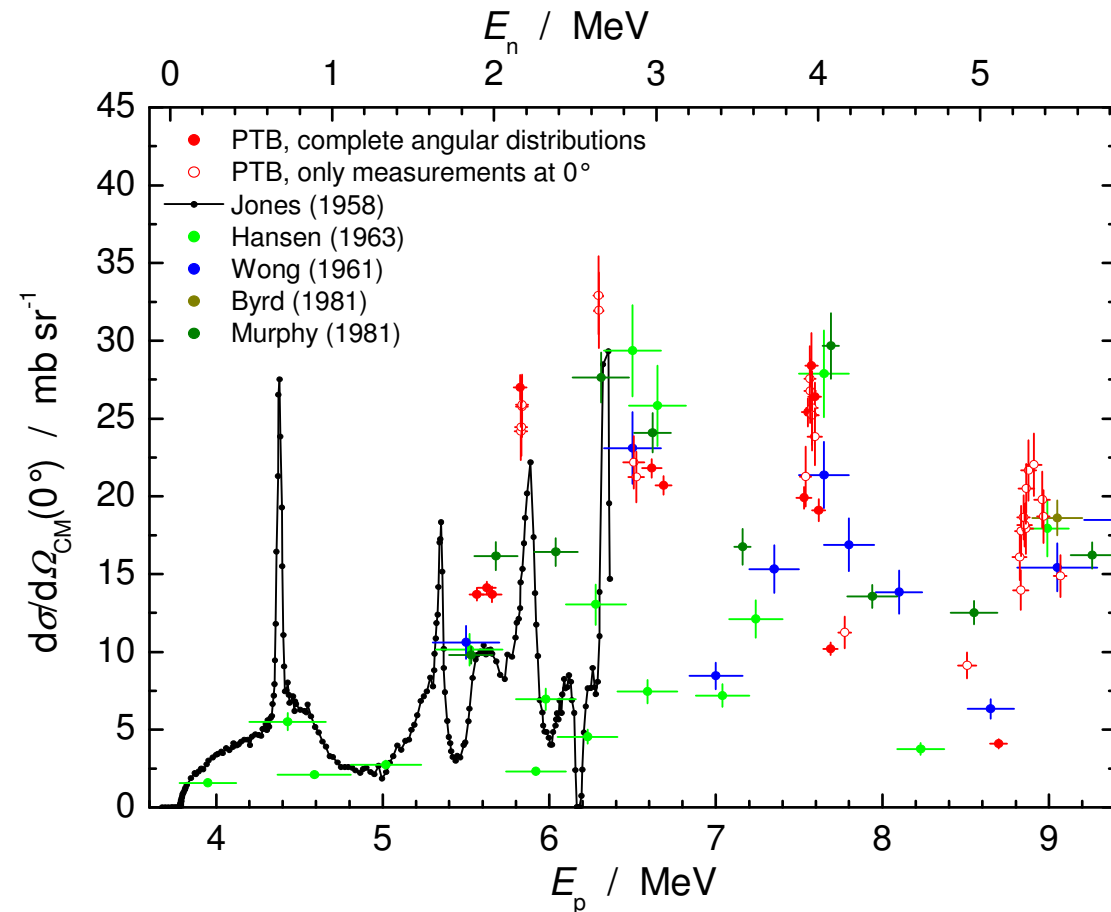

Neutron yield $dY/d\Omega(0^\circ)$ approx. one order of magnitude smaller than for $\text{D}(d,n)$ reaction!

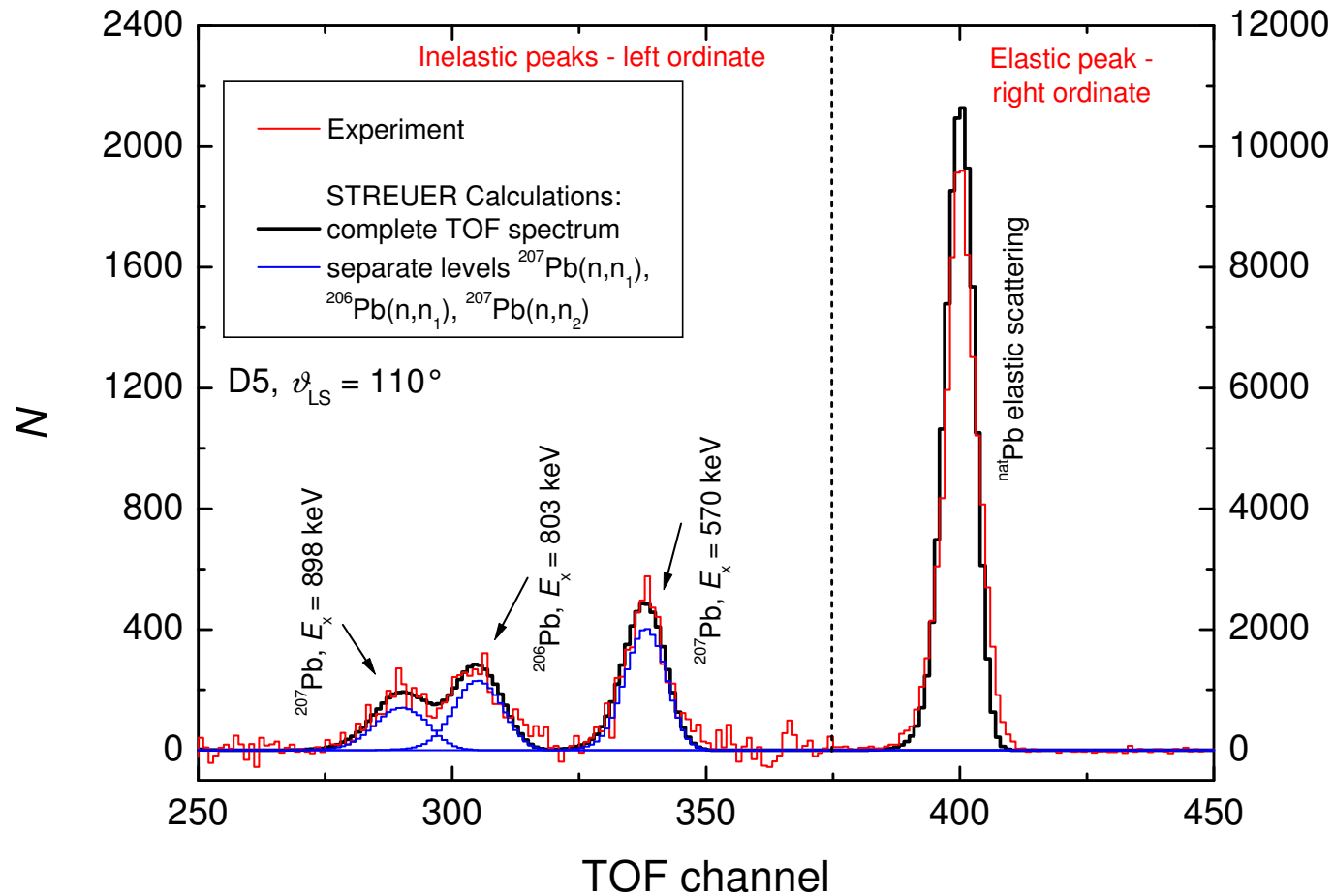

**Comparison of experimental with simulated TOF spectra:
(Monte Carlo code STREUER):
Iterative improvement of cross section data**

Results: ^{nat}Pb Elastic Scattering

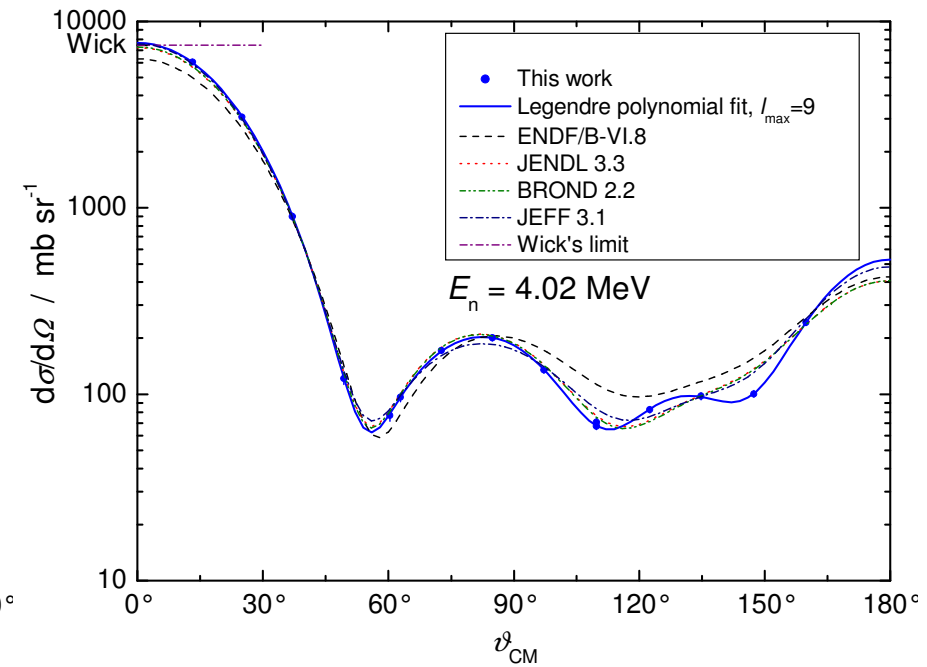
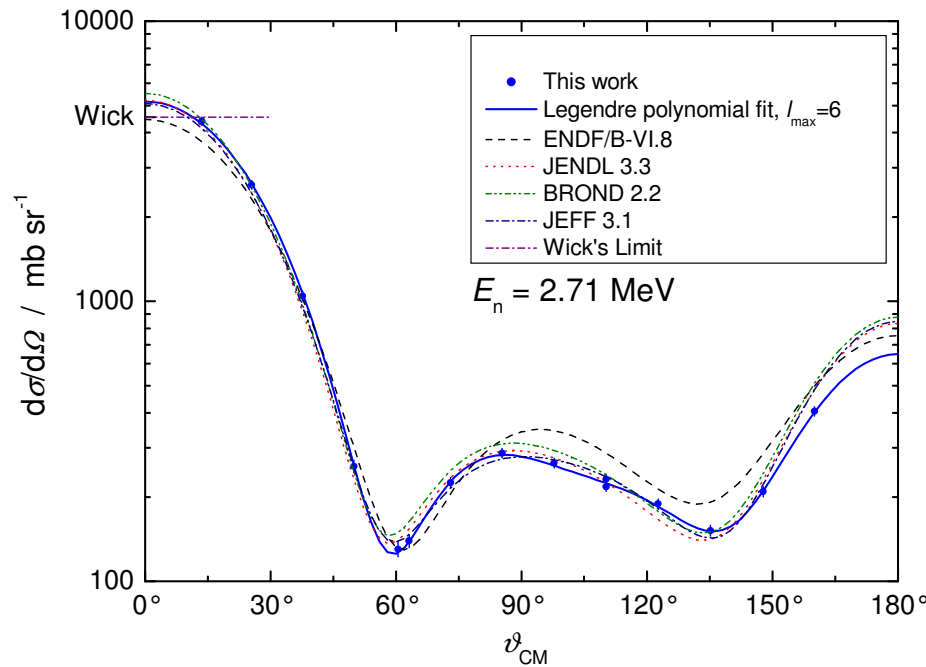

- Good agreement with angular distributions of JENDL, JEFF and BROND evaluations
- Good agreement of angle-integrated cross sections with all evaluations
- Wick's limit not fulfilled by ENDF/B-VI.8

206,207Pb Inelastic Scattering

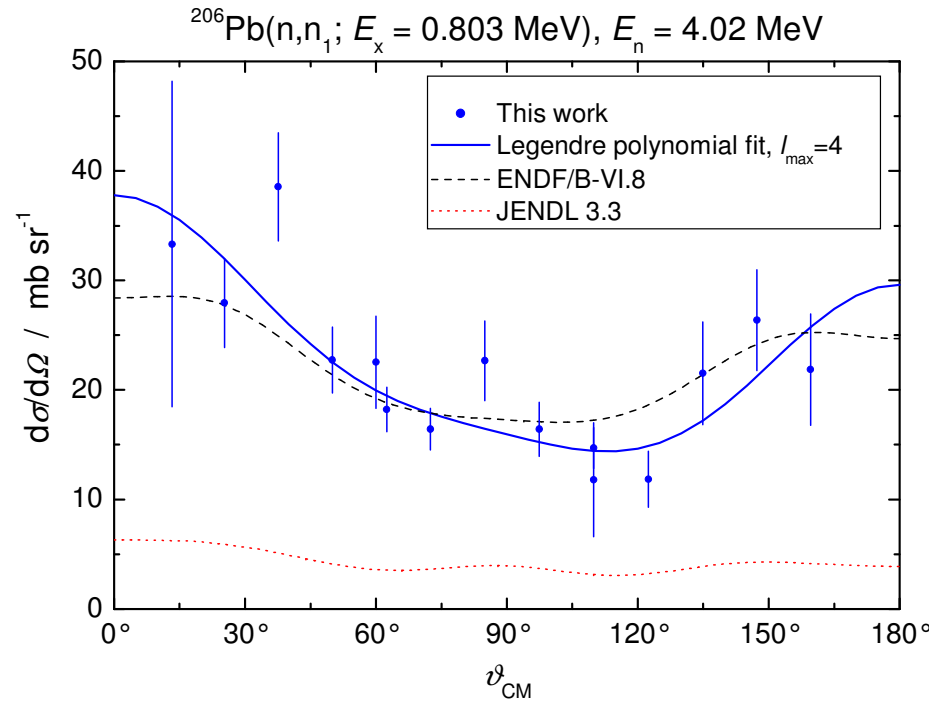
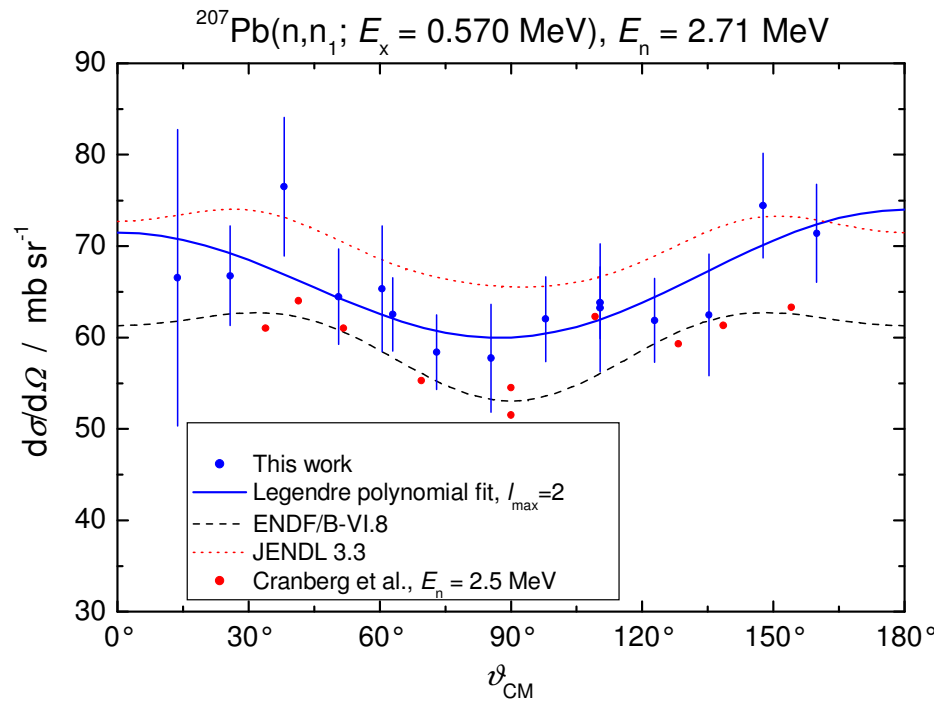

- Inelastic cross sections are smaller, only one isotope contributes
- ⇒ Uncertainties dominated by counting statistics
- Generally good agreement with ENDF, disagreement with JENDL data

$^{206,207}\text{Pb}$ Inelastic Scattering

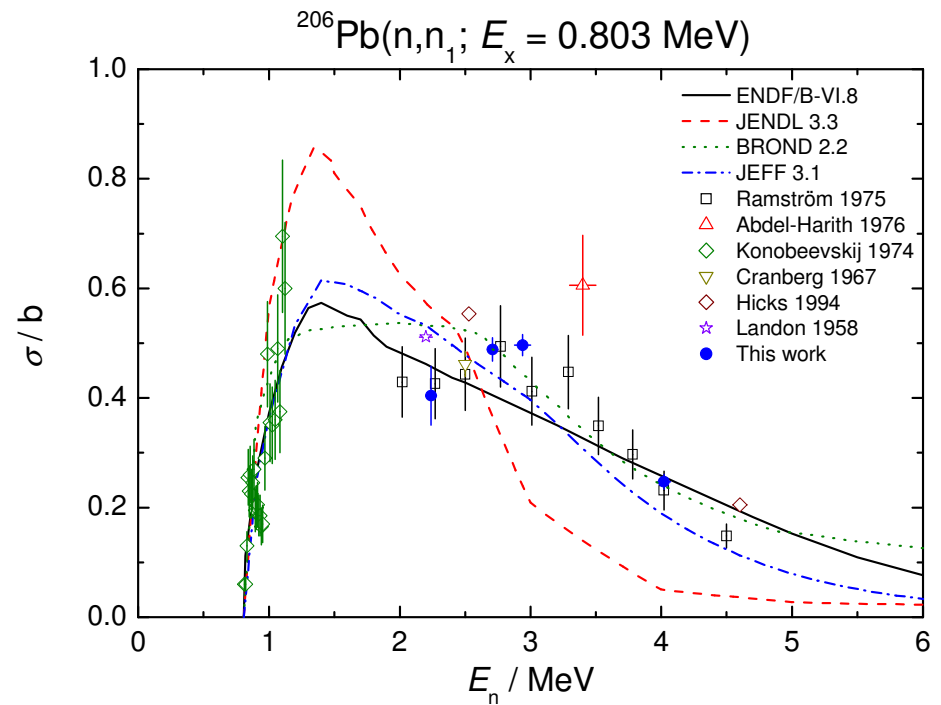
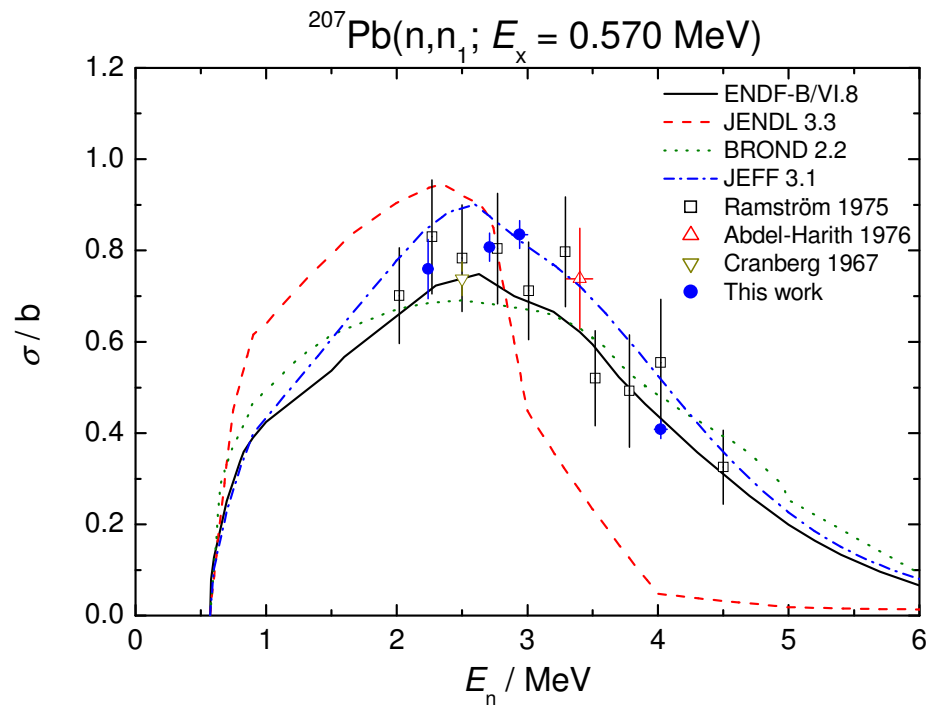

- Very good agreement with measurements by Ramström and Cranberg and evaluations ENDF, JEFF and BROND
- Smaller uncertainties than in measurements by Ramström

^{209}Bi Elastic Scattering

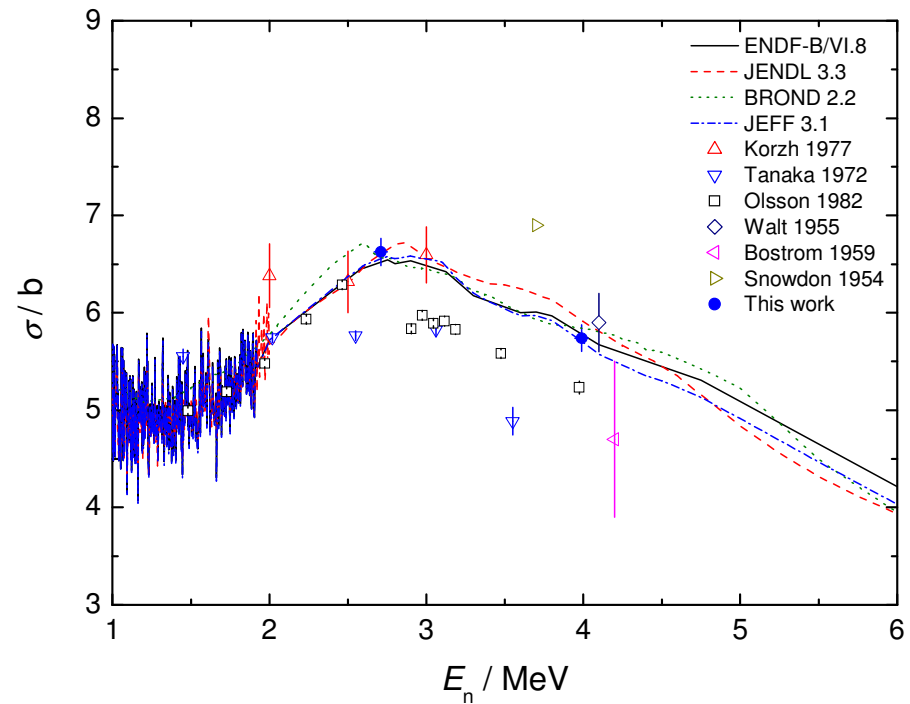
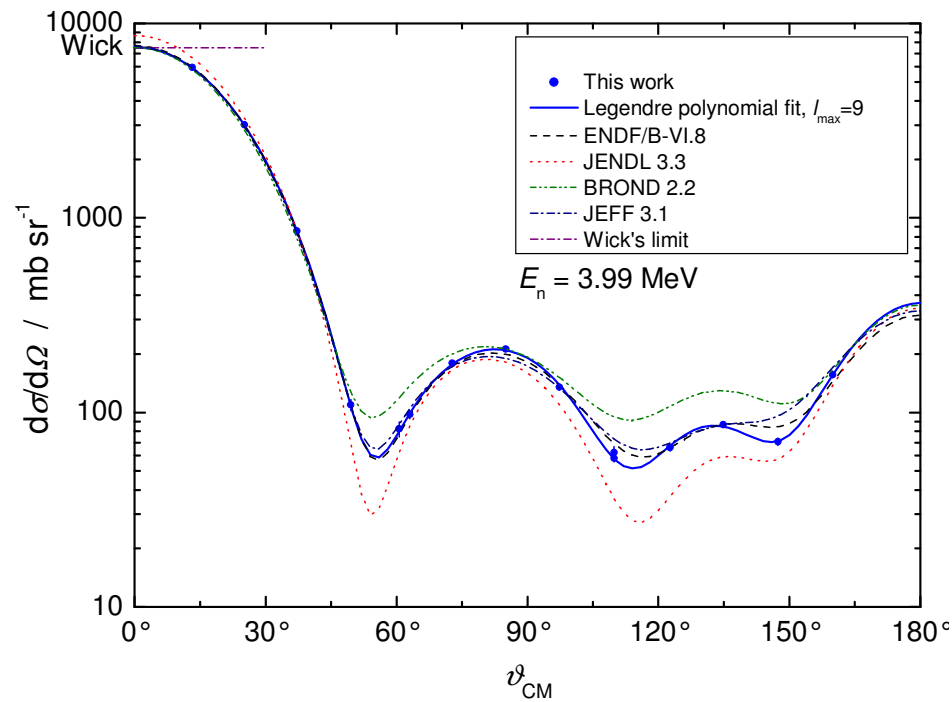

- Good agreement of differential cross sections with ENDF and JEFF evaluations
- Good agreement of integrated cross sections with all evaluations

^{209}Bi Inelastic Scattering

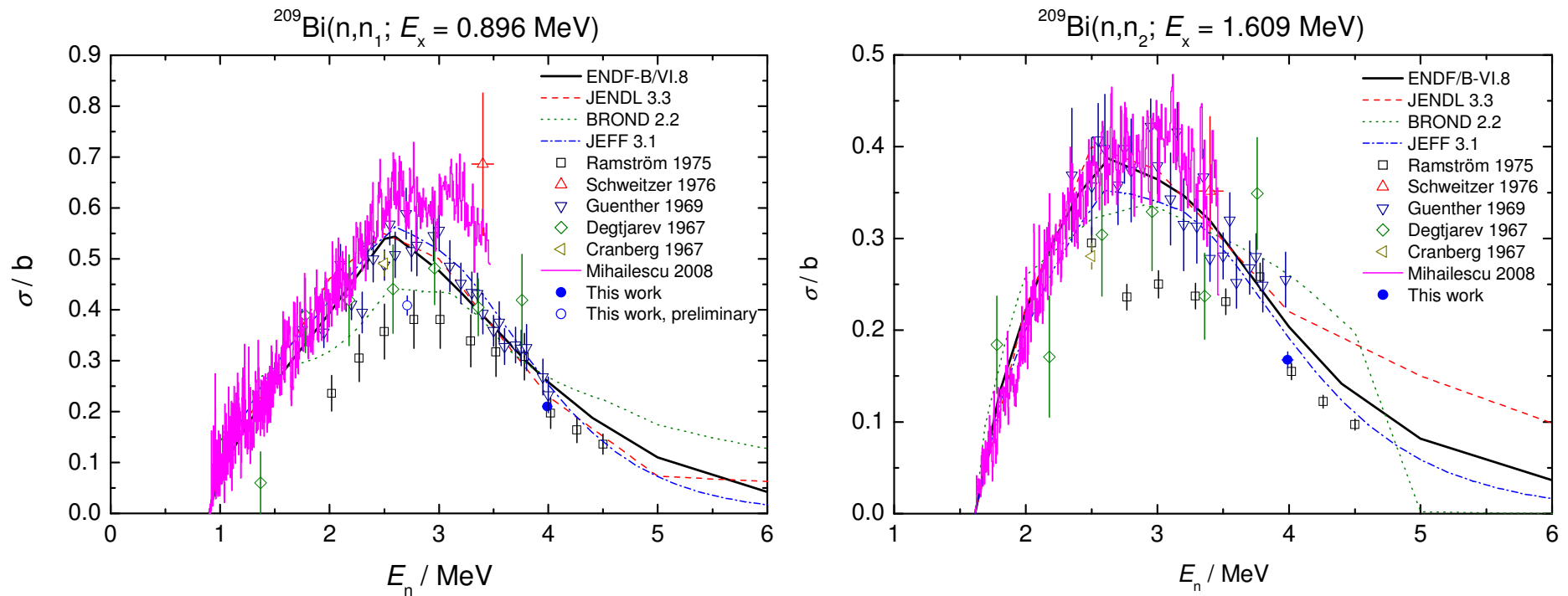

- Experimental results strongly scatter
- Good agreement with measurements by Ramström, but most other experimental data are larger.

Comparison of total inelastic scattering cross section:

$$\sigma_{\text{inl}} = \sum \sigma_{n,n_x}$$

$$\sigma_{\text{tot}} = \sigma_{\text{el}} + \sigma_{\text{non}}$$

$$\sigma_{\text{non}} \approx \sigma_{\text{inl}}, \text{ as}$$

$$\sigma_{n,\gamma}, \sigma_{n,p}, \sigma_{n,\alpha} < 1 \text{ mb}$$

$$\Rightarrow \sigma_{\text{inl}} \approx \sigma_{\text{tot}} - \sigma_{\text{el}}$$

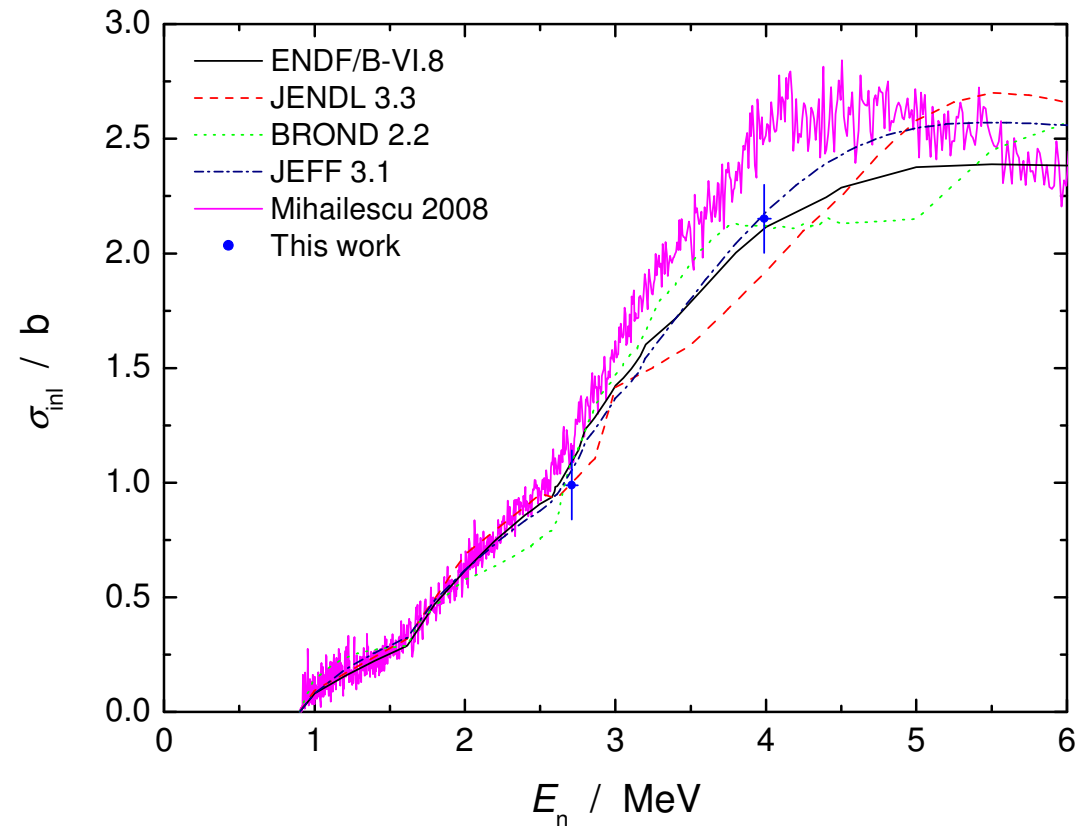

- Good agreement with evaluations
- Experimental data by Mihailescu are larger, but deviation is smaller than for level cross sections.

Measurement of scattering cross sections for $^{\text{nat}}\text{Pb}$ and ^{209}Bi

- Good agreement with measurements by Ramström, but often smaller uncertainties.
 - $^{209}\text{Bi}(n,n')$ cross sections are smaller than most experimental data.
- ⇒ $^{15}\text{N}(p,n)$ successfully used in scattering experiments, but longer measurement times are required.
-
- Data analysis for 3rd ^{209}Bi measurement
 - More measurements for ^{209}Bi ?
 - Measurement for ^{181}Ta , $E_n = 3.99$ MeV: Data analysis nearly completed.

$^{209}\text{Bi}/^{181}\text{Ta}$ TOF spectra

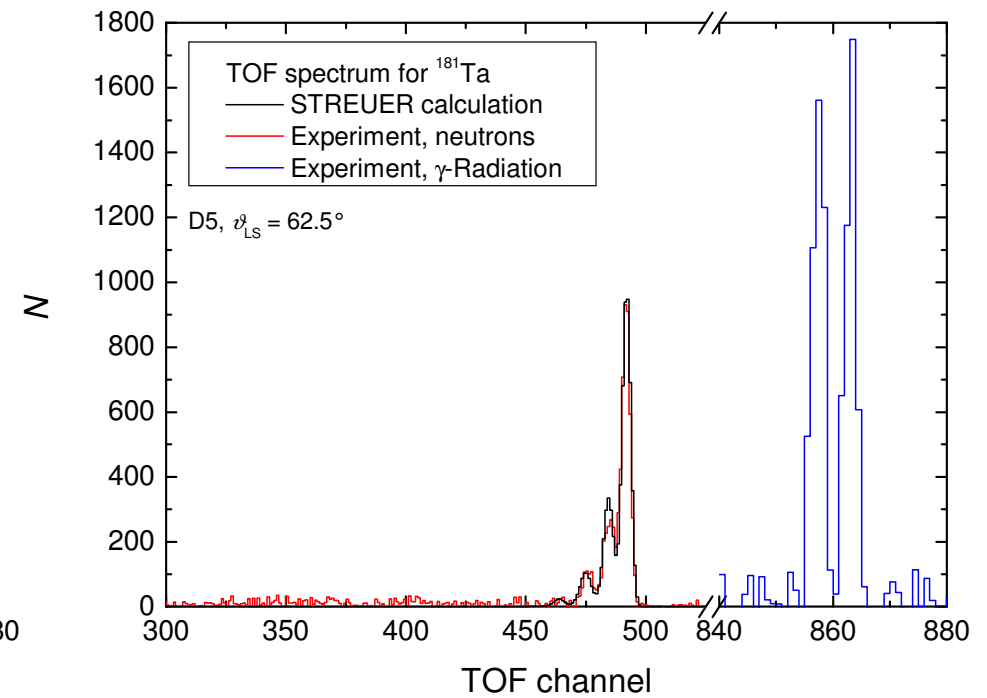
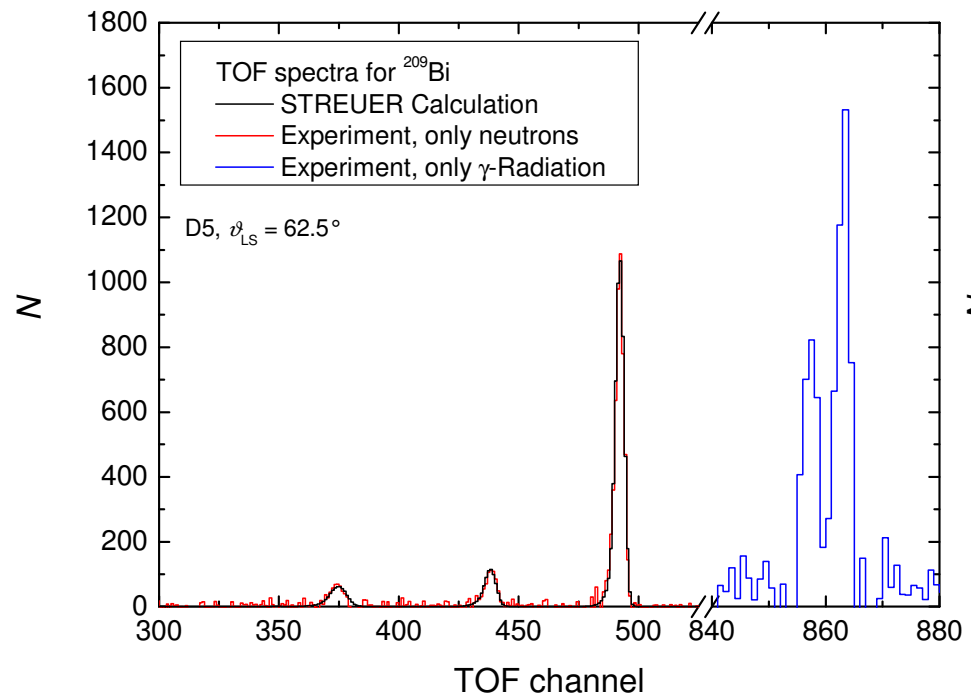

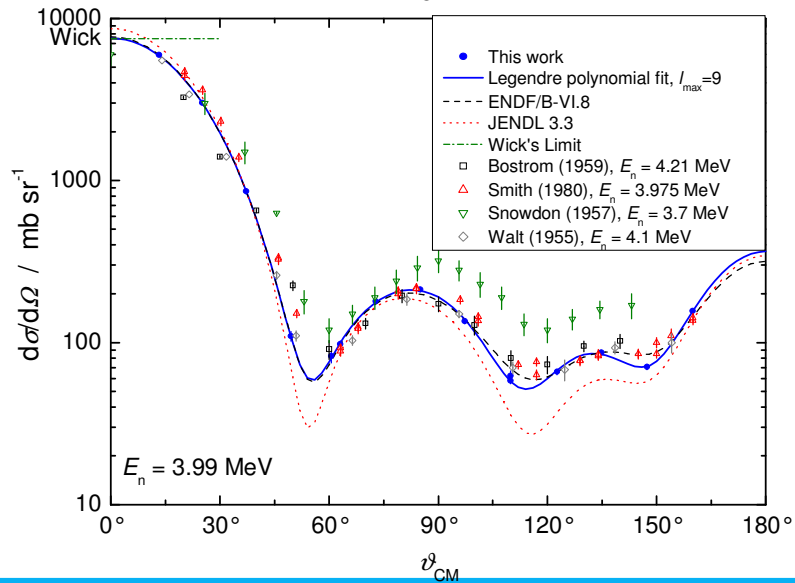
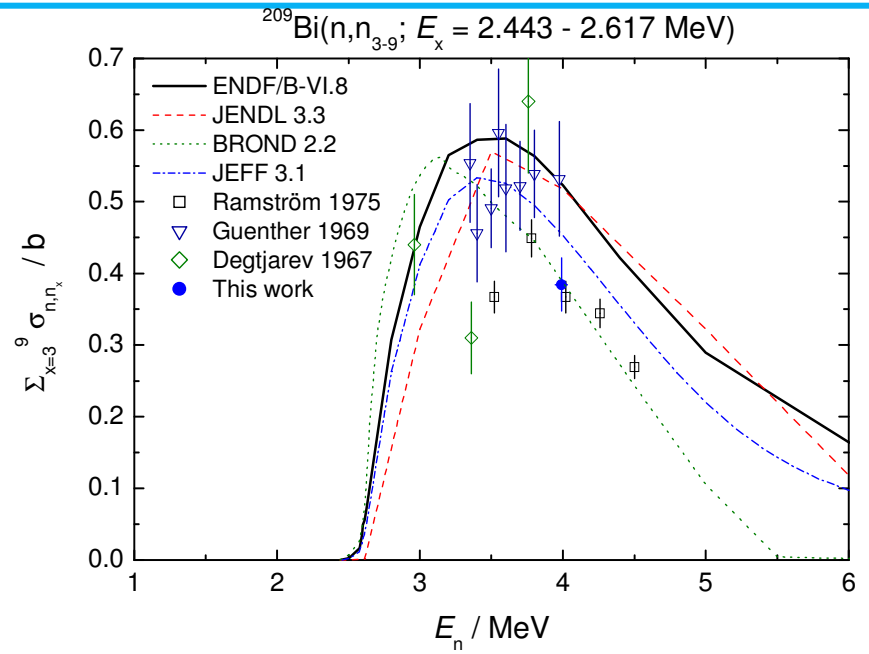
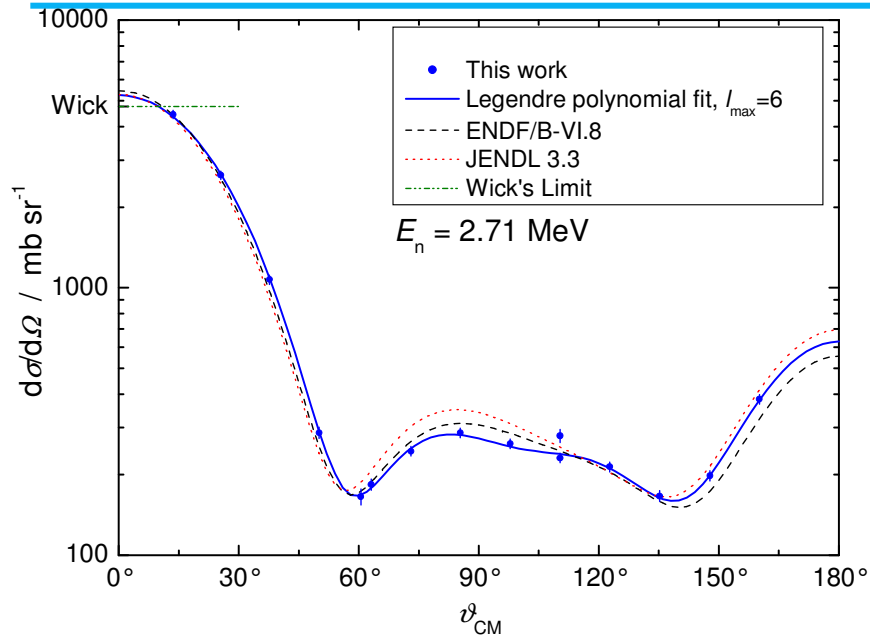

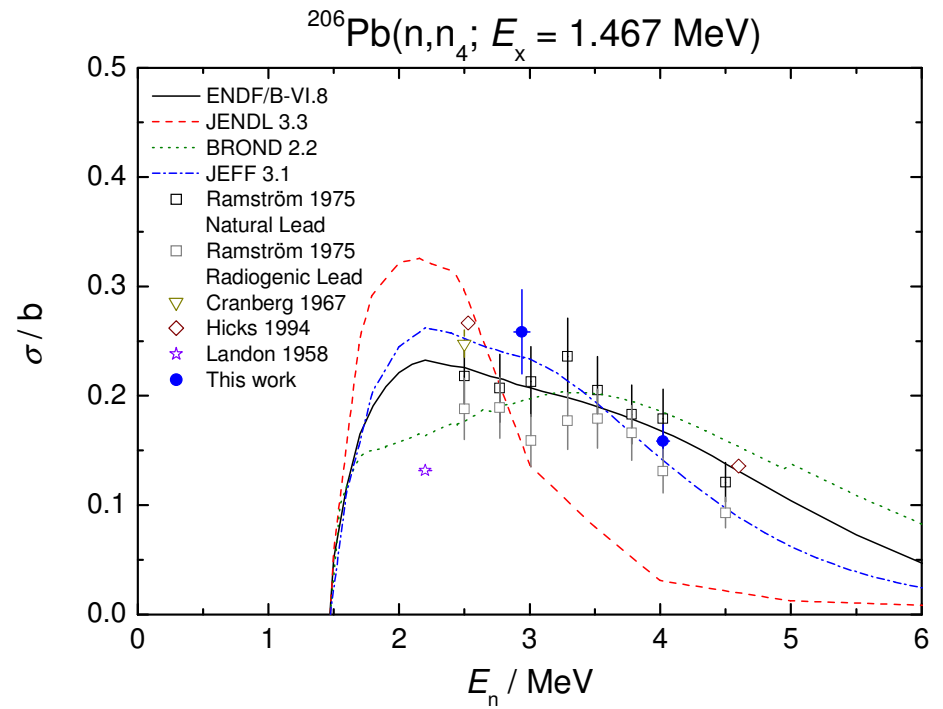
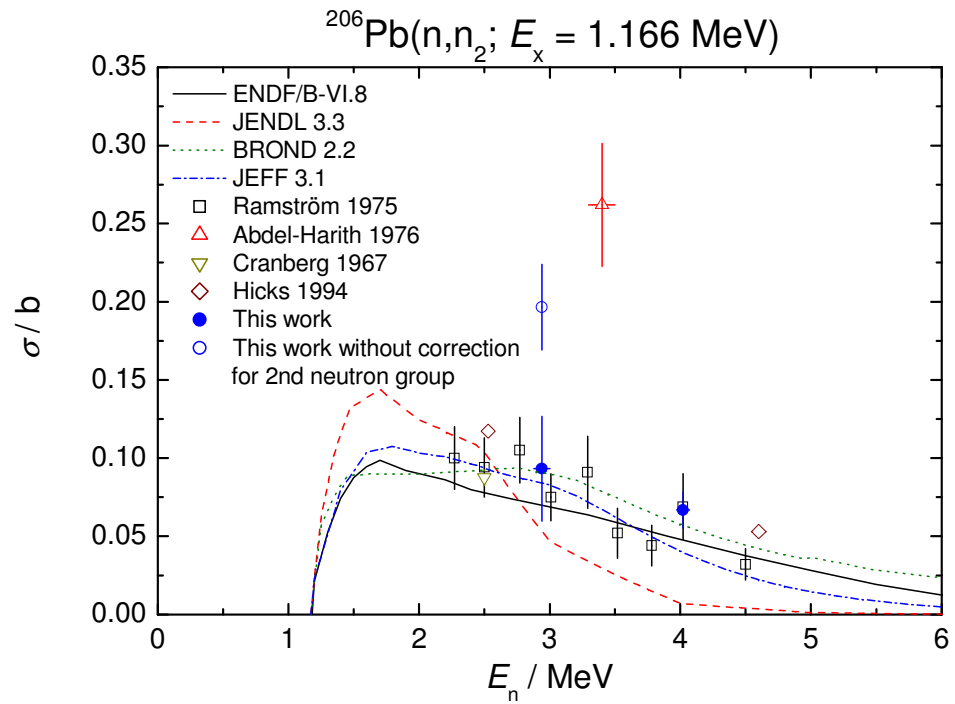

The $^{15}\text{N}(p,n)$ Reaction

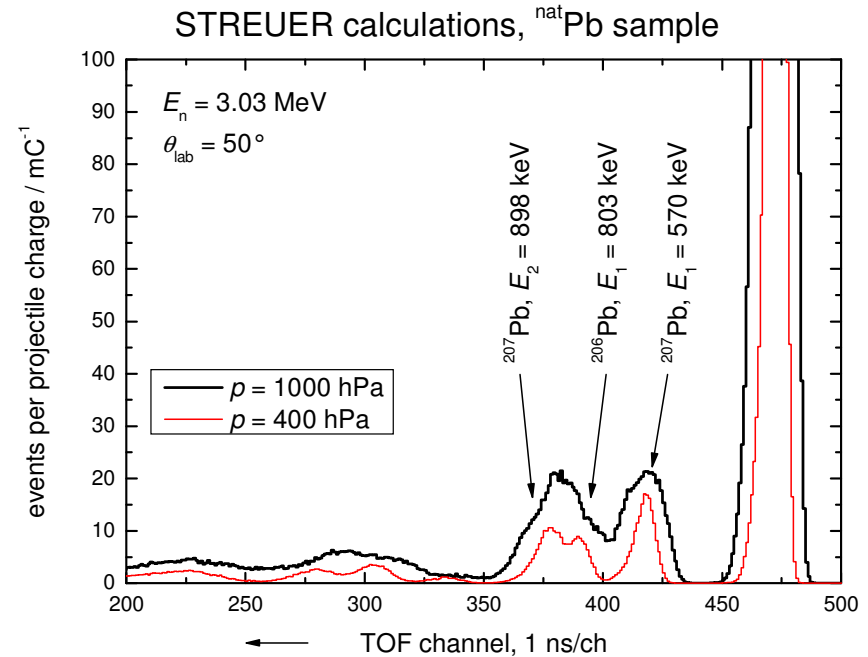
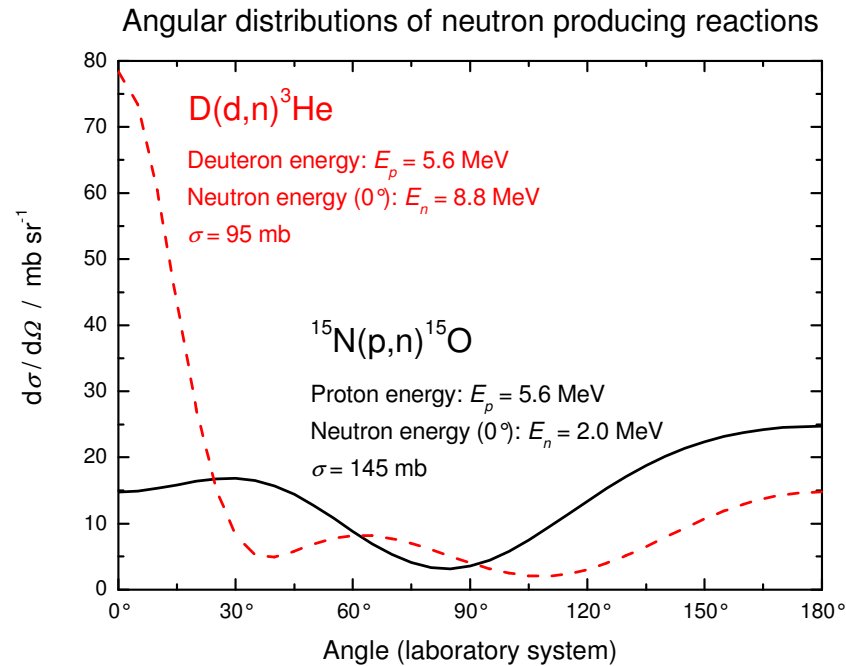

⇒ Experiments meaningful only at selected energies

⇒ Compromise between neutron yield and energy resolution

Neutron yield $dY/d\Omega(0^\circ)$ approx. one order of magnitude smaller than for D(d,n) reaction!

Neutron TOF Spectra

TOF spectrum, D(d,n) neutrons, $E_n = 12.00$ MeV

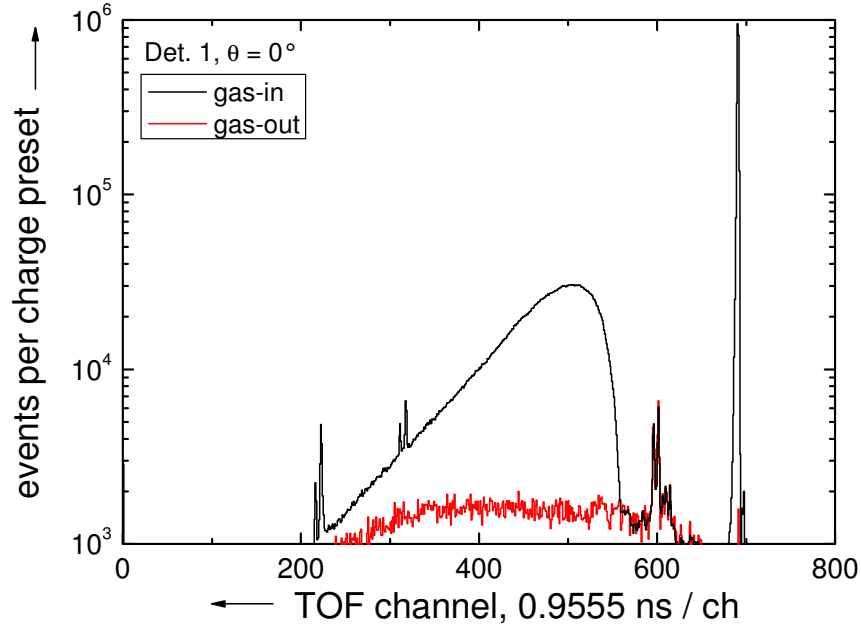

TOF spectrum, $^{15}\text{N}(p,n)$ neutrons, $E_n = 2.94$ MeV

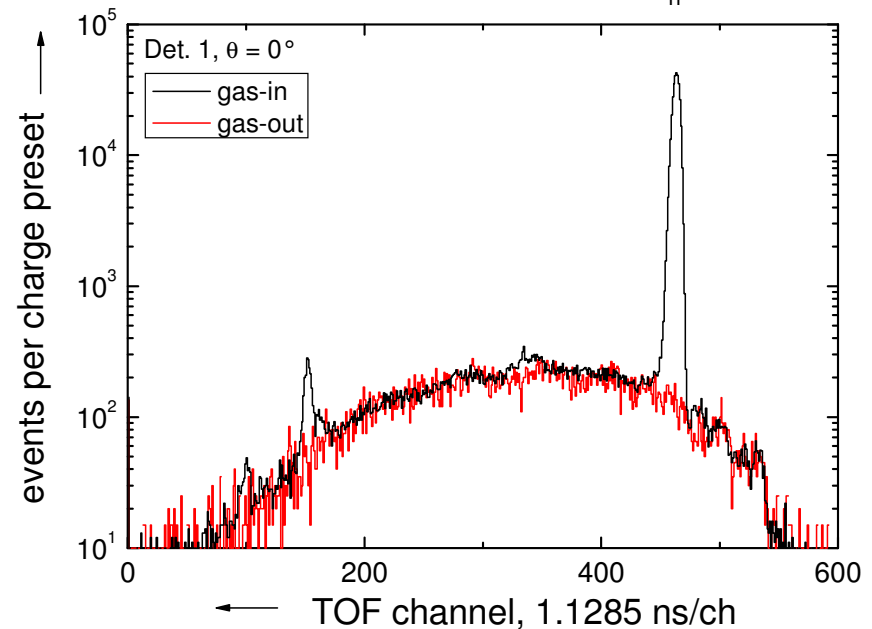

Quasi-monoenergetic neutrons require additional corrections.

2nd neutron group ???

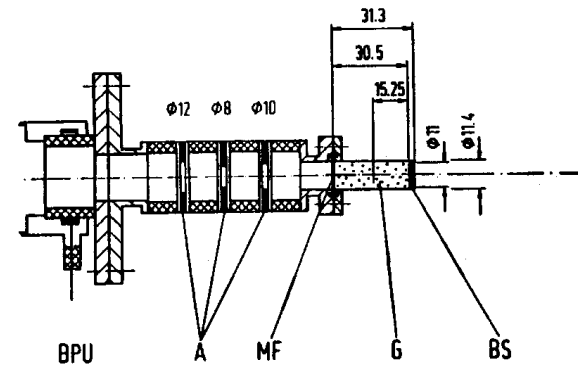

Neutron TOF Spectra

TOF spectrum, Experiment, $E_n(0^\circ) = 2.94$ MeV

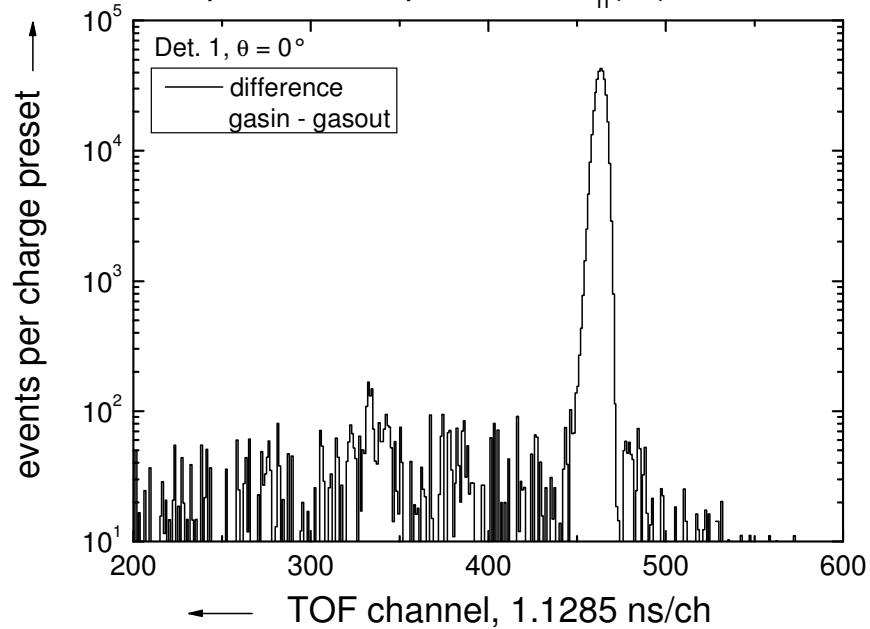

TOF spectrum, MCNP simulation

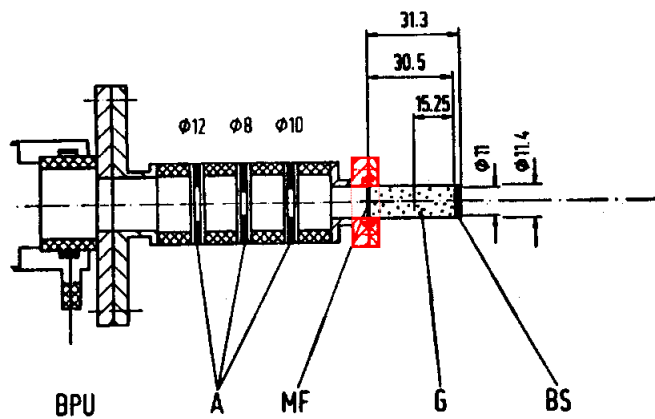
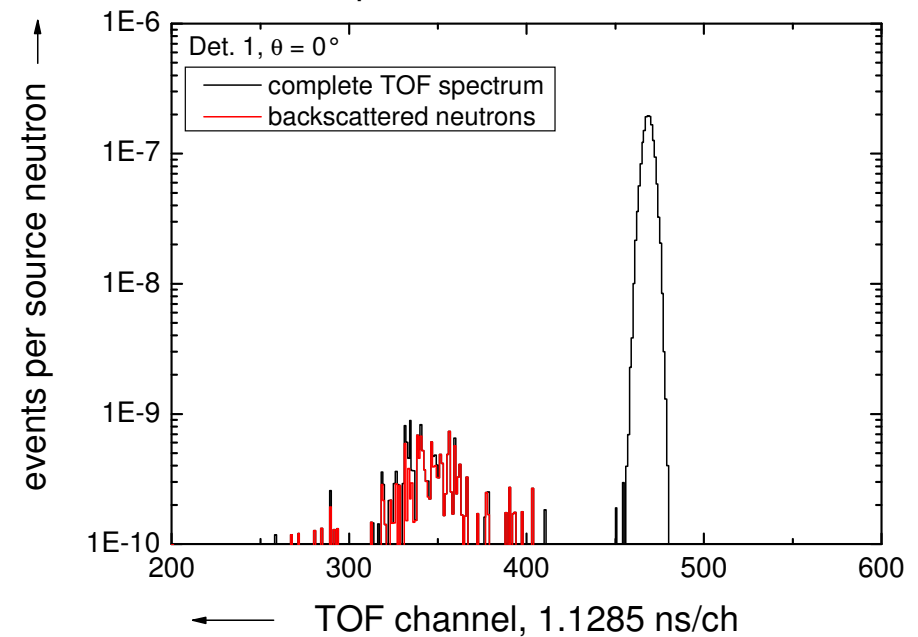

⇒ Neutrons emitted in backward direction and scattered in forward direction